

# Magnum Cv<sup>®</sup> and Magnum Cv PLUS<sup>®</sup> Start-up Checklist

## Read This for a Quick and Trouble Free Start-up

This sheet is an extension of the installation manual. It is an aid to ensure a trouble free start-up.

### Tank and Valve Piping Alignment

With an empty tank, screw the Magnum Cv valve onto the top of the mineral tank and tighten. Align the tank in the desired position so that the plumbing aligns with the inlet and outlet ports of the valve. Also make sure that the control is easily accessible for programming purposes. Remove the Magnum Cv valve and fill the media tank with media. Follow the tank manufacturers' recommendations concerning the installation of vacuum breakers and flexible tubing.

### Correct Flow Controls

Make sure that the proper DRAIN LINE FLOW CONTROL, REFILL CONTROL and INJECTOR are installed with the Magnum Cv. Refer to the service manual for properly sized flow controls.

### Pilot and Auxiliary Ports

There are two ports located in between the principle chambers of the Magnum Cv valve, Figure 1. Both are labeled on the valve body. The PILOT drain should be plumbed to a non-pressurized drain or open to atmosphere. Any backpressure or plugging of the PILOT drain can cause the valve to malfunction. The AUXILIARY port will come from the factory plugged. Leave the plug in place if the port will not be used. Refer to the service manual for AUXILIARY port operation.

### Mounting Timer or Meter Control

When mounting the control to the valve body it is very important the timer and camshaft be in the correct position. If they are not correct, the unit will not function properly. The pillow block arrows must line up with the camshaft arrow for proper installation

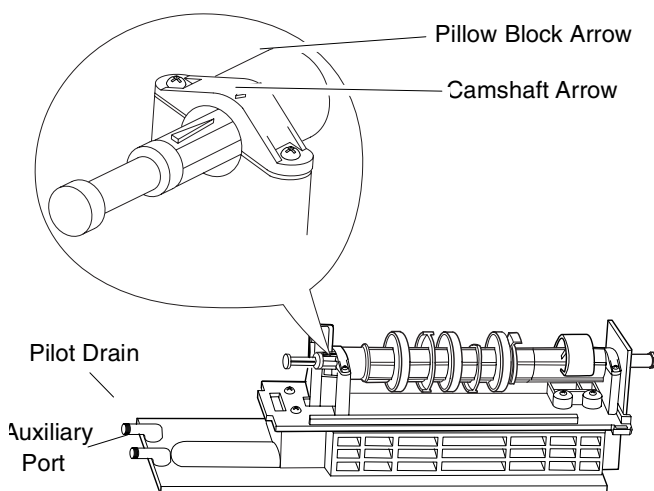

Figure 1

(Figure 1). This alignment allows the camshaft to be pulled back so the front of the camshaft is flush with the mounting bracket for the timer control. Prior to engaging the camshaft, move the control to the Service position and slide the control onto the valve. Engage the camshaft into the back of the control.

### Check Operating Pressure

The system will not operate properly with less than 25-psi pressure in the pilot system. If you do not have sufficient pressure an alternate source may be required. Using an external pilot feed adapter, P/N 1040668, an alternate source of clean water or oil-free air can be used as long as the pressure is greater than that of the inlet pressure and at least 25 psi. Refer to the Service manual for installation of the pilot feed adapter.

### Follow Start-up Procedure

If the previous steps have been checked you are ready for start-up of the system. The directions for this procedure and programming of each control can be found in the Magnum Cv Installation and Service Manual.

### After Start-up

If the unit has a constant flow to drain after the previous steps have been checked and the start-up procedure has been completed, one or more of the following may be the cause:

- The control is not stopped in the service position.
- One or more of the start-up steps from this sheet has not been met.
- Is the service of the outlet emptying into a storage tank that is at atmosphere? A flow control throttling valve may be required to limit the flow through the system for proper treatment of the water and allow pressure to build in the pilot system of the Magnum Cv.
- Verify proper installation of the control. When the control is in the service position you should be able to slide the camshaft back and lift the control off of the valve. If you can not do this, look to see if the arrow on the camshaft and the arrow on the support clamp line up (see diagram).